

Tracewell S33-1U for CompactPCI

2-slot Rugged Rack/Benchtop System

Description

The Tracewell S33-1U is the industry's highest performance 2-slot 1U cPCI chassis. Featuring increased power and cooling, system monitoring, and a rugged machined design, S33-1U is ideal for the latest generation of high-performance processors used in government/military and data/telecom applications.

To accommodate the heat generated by high-density boards, the S33-1U employs a push/pull cooling scheme providing cooling for up to 75 watts for each of two cPCI slots. The unique push/pull design provides the added pressure performance needed to overcome the backpressure of these highly restrictive boards. The result is evenly distributed cooling and minimal temperature rise. A 250-watt power supply provides high current 5V and 3.3V current as well as isolated cooling.

To help maintain critical power and cooling operating conditions within the chassis, the S33-1U employs enhanced processor-based monitoring. Allowing greater flexibility and software control, it is particularly useful in remote monitoring applications. A serial interface and front panel LEDs provide real-time temperature and voltage status to the user.

The S33-1U provides greater stiffness than similar 1U chassis due to its unique machined design. Rather than thin formed steel, the S33-1U top and bottom covers are machined from 0.125" aluminum. This approach allows for thick material to be used in most areas other than the shielding interface resulting in less flexure and better heat distribution.

Tracewell's S33-1U provides the solution for critical high-performance applications where cooling and robust design are a must.



Features

- True-1U rugged machined designed
- Advanced push-pull cooling for up to 75W per slot
- Multi-point temperature monitoring
- 2-slot cPCI backplane with IPMI capability
- Software-based monitoring with serial interface
- EMI shielded design
- 24 and 48VDC input options available
- Ideal for high-wattage processors



Physical

Construction:	Aluminum sheet, 5052-H32 alloy; top and bottom covers (.125") Steel sheet, ASTM A366; front/rear upper/lower cardcages (.060"), sides (.050") Aluminum Extrusion, 6101-T6 alloy; cardcage front profile Cardguide, snap-in, .062" pcb thickness, nylon, UL 94V-2 flame rated material Cardguide entry, snap-in, .062" pcb thickness, nylon, UL 94V-0 flame rated material Front door, .125" thickness, tinted, GE Lexan 500, UL 94HB flame rated material
Cardcage:	Front: 6U x 160mm, recessed, 2 slots, IEEE 1101.10; Rear: 6U x 80mm, recessed, 2 slots, IEEE 1101.11 compliant
Dimensions:	14.68" D (373 mm) 17.31" W (440 mm, less rack flanges) 19.00"W (483 mm, including rack flanges) 1.72"H (44 mm, 1U)
Weight:	15 lbs. (6.8 kg)
Finish:	Textured paint, carbide black; all exterior surfaces; All other aluminum is brushed clear chromate per MIL STD 5541, steel is brightzinc plate
Additional:	(2) removable rack flanges, (4) removable feet, (1) removable linecord, removable/hinded tinted polycarbonate front door

Backplane

Bus Structure:	CompactPCI 64-bit, 33/66 Mhz, System slot left
Assembly:	SMT/ press-fit assembly
Layer count:	8 layers
Control:	System header for PRST#, DEG#, FAL#, return and remote sense for +5, +3.3, +/-12VDC, IPMI header per PICMG 2.9
PCB construction:	FR4 epoxy-glass laminate, multilayer, all-stripline, SMOBC, silkscreen on two sides, 1oz. copper signal and power planes minimum, UL 94V-0, .150" (3.8 mm) thickness
Impedance (Z_0):	65 Ohms nominal on all signal lines, non-loaded pcb
Decoupling:	SMT decoupling per PCMI 2.0 R2.1
Rear shrouds:	Extended rear tails and shrouds on all P3 - P5 connectors
DC distribution:	Screw terminals for +5, +3.3, return (35A rating per terminal), spade terminals for +/-12Vdc and V I/O (15A rating per terminal)
Compliance:	PICMG 2.0 R3.0, hot swap compatible per PCMI 2.1, IPMI compliant per PICMG 2.9

Power *

Total output:	250 watts; maximum for all outputs combined
Input:	90 - 265VAC with active PFC
Frequency:	47 - 63 Hz
Efficiency:	>65% typical at full load
Input current:	6A at 120VAC; 3A at 240VAC
Inrush current:	30A peak at 115V; 60A at 240VAC
Hold-up time:	17mS minimum
DC outputs:	+5.0V/ 25A, +3.3V/ 20A, +12V/ 12A, -12V/ 0.5A, -5V/ 0.5A, +5VSTBY/ 3A (combined output of 5V and 3.3V shall not exceed 150W)
Minimum Load:	None
Protection:	Overvoltage and overcurrent; automatic recovery

Cooling

Airflow: Front intake, side exhaust, push-pull design; chassis and power supply are cooled independently
Fans: (7) 15 CFM, high pressure tube-axial, 12Vdc
Performance: 350 LFM per slot (free air); demonstrated cooling for up to 75W per slot at 55 deg C
Control: Temperature-based speed control

Control and Input

Switches: Rear panel on/off
Power input: Rear panel IEC320 inlet connector
Circuit protection: Power supply internal breaker resets by cycling AC or front panel on/ standby switch

Monitoring

Interface: Front panel LED visual indicators; rear panel RS232 interface
Functions: Power: DC output over and under voltage verification for PS outputs +5, +3.3, +12, -12VDC; acceptable output range is +5 to -3%; monitor provides global DC okay/fail as well as individual voltage readings
 Temperature: 3 temperature sensors measure exhaust air temperature (2 for front subrack, 1 rear); overtemperature warning at 60 deg C; monitor provides global Overtemperature okay/fail as well as individual temperature sensor readings
Outputs: Front panel: global DC okay LED (green; on=okay, off=fail), Overtemperature LED (red; on=fail, off=okay)
 RS232 Output: Rear panel 9-pin (AMP #747321-4): provides global DC okay and temperature status as well as providing specific voltage and temperature readings for all sensors
 All output warnings are latching and drive both a front panel LED state change and RS232 fail command; auto-recovery after fault removed
 Specific voltage and temperature readings must be polled by user (consult factory for command set)

Environmental

Temperature: 0°C to +55°C operating; -40°C to +70°C non-operating
Shock/ Vibration: Basic transportation
Humidity: 5 – 95% non-condensing at 40°C operating, 0 – 95% non-operating
Acoustic: < 58 dBa (1 meter) with fans at low speed; < 70 dBa full speed

Agency Compliance **

Designed to meet or exceed the following:

Safety: UL/cUL
Emissions: FCC Part 15, subpart B class B and CISPR 22

Warranty

1 year limited warranty

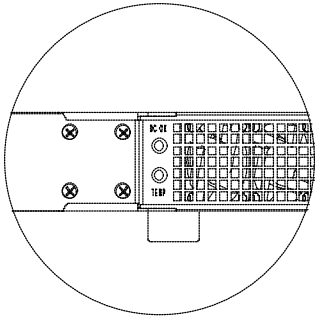

FRONT PANEL DETAIL

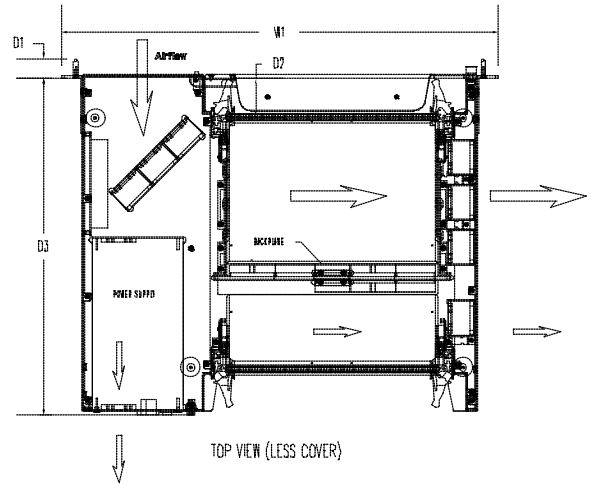

TOP VIEW (LESS COVER)

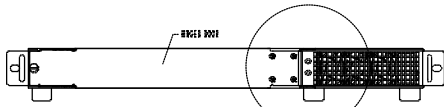

FRONT VIEW



SIDE VIEW

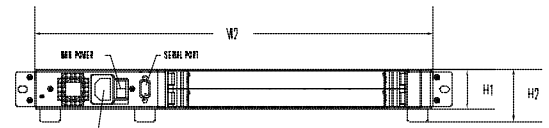

REAR VIEW

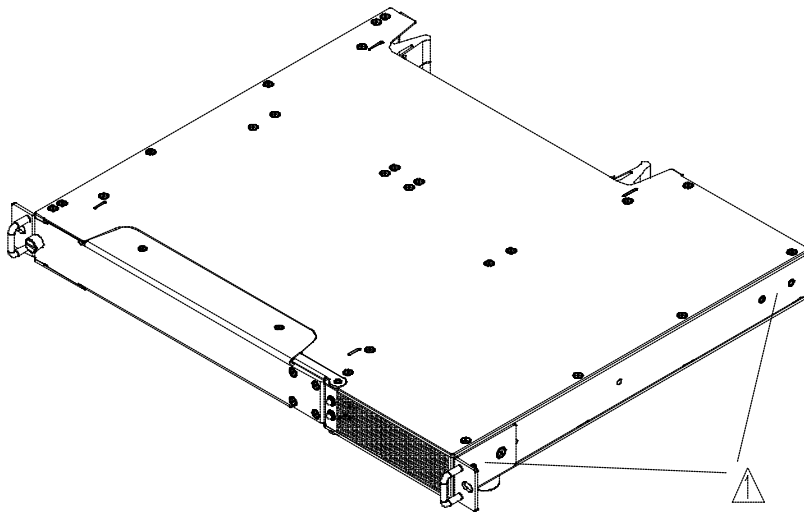

SERIAL PORT PINOUT		
PIN	ID	
1	NC	
2	RXDA	
3	TXDA	
4	PIN 6	
5	GND	
6	PIN 4	
7	RTSA	
8	CTSA	
9	NC	

Dimensions:		
D1: 0.84" (21 mm)	W1: 19.00" (483 mm)	H1: 1.72" (44 mm, 1U)
D2: 1.72" (44 mm)	W2: 17.31" (440 mm)	H2: 2.25" (57 mm)
D3: 14.68" (373 mm)		

Notes:	
△	Rack flange alternate rear-mount location

Ordering Information

The S33-1U is available in the following standard configurations:

Part number	Description
533-6050-F00-00	Tracewell S33-1U for cPCI,2-slot,250W,M2

Accessories

014-6001-001-0P	Shielded single-slot filler panel, 6U X 4T; installs in vacant slots
-----------------	--

Notes:

- * Additional power supply options including 24 and 48VDC input available. Consult factory for more details.
- ** Agency compliance applies to the power supply only, as shipped from Tracewell Systems. As an option, Tracewell Systems can evaluate agency compliance for the customer's specific integrated product. Consult factory for more details.

request a quote at our web site:
www.tracewellsystems.com

or call: 1.800.848.4525

© Copyright Tracewell Systems, Inc. 2002

Tracewell Systems, Inc. reserves the right to make changes without notice.
All brand or product names may be trademarks or registered trademarks of their respective holders.
Please consult Tracewell Systems for any special or custom requirements.

P/N 095-6028-000-0P Rev. 4 10/04