

E-Tool Mobile Manager

11 Drawer - Rugged - Passive

Description:

The Tracewell E-Tool Mobile Manager is the answer to Defense and Commercial Industries' initiative to implement and field electronic media platforms reducing the reliance on traditional paper bound manuals providing a reliable and secure path for Interactive Electronic Tech Manuals (IETM). Tracewell's objective is to provide a storage, transport and charging system with a single point LAN connection for a wide variety of E-Tool platforms that is light weight, efficient, durable and cost effective.

Features:

- Accommodates a wide variety of rugged laptops, PDAs and power supplies
- Drawers are vented to allow warm air to escape
- Power surge protection is provided to protect electronics from voltage spikes
- Durable chassis finish
- All drawers are lockable from with a single padlock
- One drawer open feature – allows for a single drawer to be open at a time to prevent the cabinet becoming unstable
- Equipped with an Ethernet switch, allowing for a single network connection
- An additional AC outlet is provided on the rear of the unit near the top to accommodate a multiple battery charger. Chargers not included.
- Fans are standard to insure sufficient cooling while charging
- Large over-sized storage drawer
- Stable reinforced chassis when empty and fully loaded
- Heavy duty casters for easy maneuvering / transport
- A single power cord provides power to all the drawers and plugs directly into a standard 120VAC, 50-60Hz wall outlet



Ordering Information:

Tracewell Part number

510-1228-F00-00

Description

E-Tool Mobile Manager, 11 Drawer,
Rugged, Passive

Specifications

- Input Voltage:** 120VAC (nominal), single phase; includes surge protection
- Input Frequency:** 50/60 Hz (nominal)
- Input Current:** 15 amps (maximum, steady state), circuit breaker protected
- Inrush Current:** Variable, depending on customer installed hardware
- Output Power:** 14.5A combined drawer output (maximum, all 10-drawers combined)
- Drawer Outlets:** Each drawer includes one (1) AC convenience outlet; each drawer is current limited to 3A
- Rear Outlets:** One (1) rear panel convenience AC output; current limited to 3A
- AC Outlets:** NEMA 5-15R, 3-pin with ground, non-isolated voltage (tied directly to input)
- Drawer LAN:** Each drawer includes one (1) 10/100Mbps Ethernet port (RJ-45); drawer Ethernet ports route through one internal Ethernet switch
- Cabinet LAN:** Rear panel, three 10/100Mbps Ethernet port (RJ-45);
 - a) connected directly to Ethernet switch
 - b) allows for daisy chaining units together
 - c) for a console port if a managed switch is used
- Dimensions:** 26.6"(D), 19.7"(W), 56.0"(H, with casters)
- Weight:** ~120 lbs. (empty)
- Temperature:** 0 deg. C to +50 deg. C (operating)
- Humidity:** 5 - 95%, non-condensing

Options

- Encrypted wireless
- CAC reader
- Variety of electrical and mechanical locking features
- RFID
- Software drawer asset administration

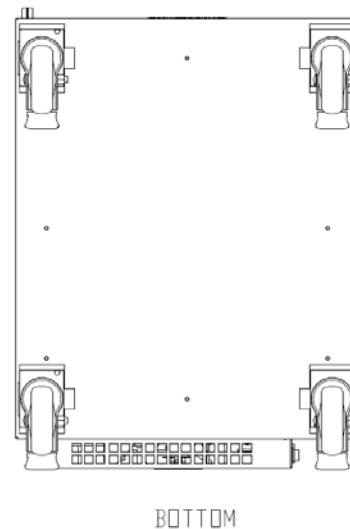
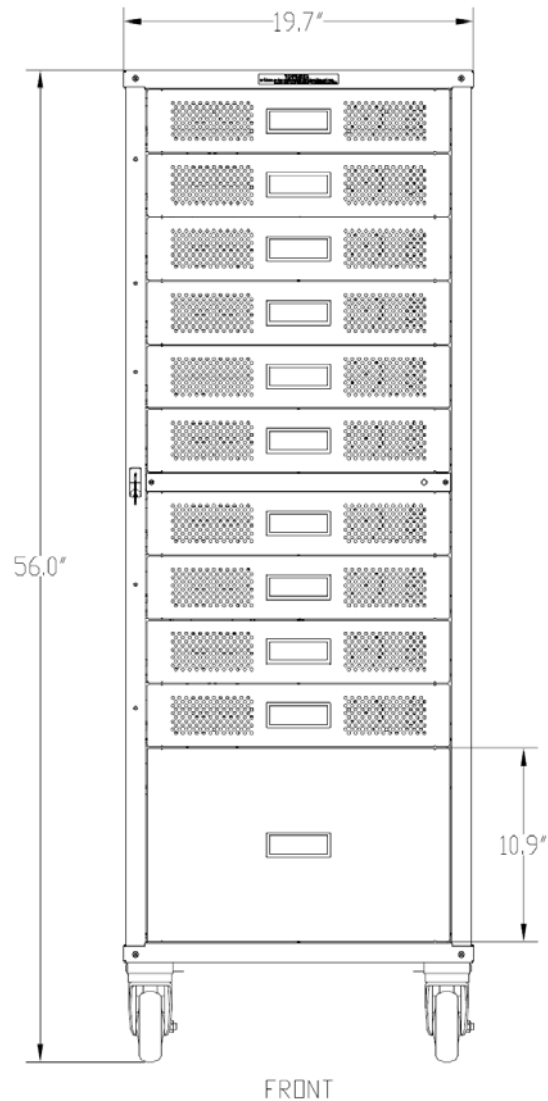
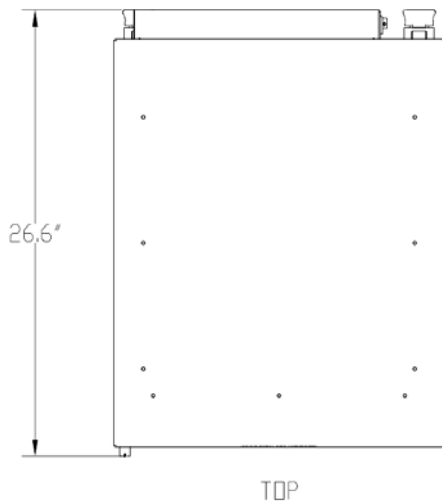

© Copyright Tracewell Systems, Inc. 2009

Tracewell Systems, Inc. reserves the right to make changes without notice. All brand or product names may be trademarks or registered trademarks of their respective holders.

Please consult Tracewell Systems for any special or custom requirements.