

E-Tool Mobile Manager, 14 Drawer, Managed

The Missing Piece To Your Electronic TOs Implementation!



Features;

- *Charges up to 14 Laptop Computers Simultaneously*
- *Network Connections and Power Provided to Each Tray*
- *Secures E-Tools for Transport*
- *Managed Ethernet Switch*

Cabinet Dimensions

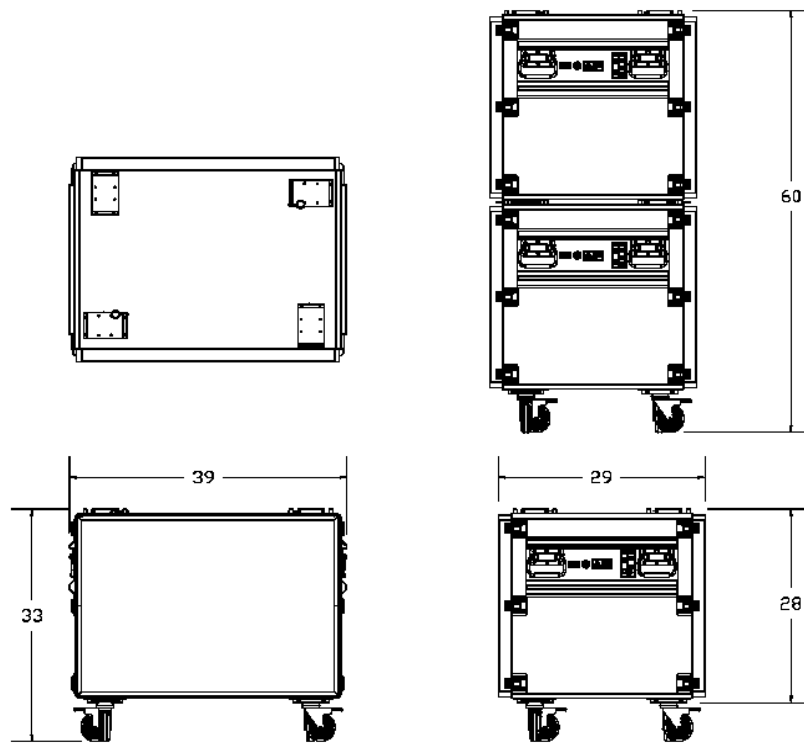

Ordering Information

Part # 510-1106-F10-00 : 2 Ethernet Ports per Drawer

Part # 510-1106-F20-00 : 1 Ethernet Port per Drawer

Light Weight, Strong and Ready To Deploy!

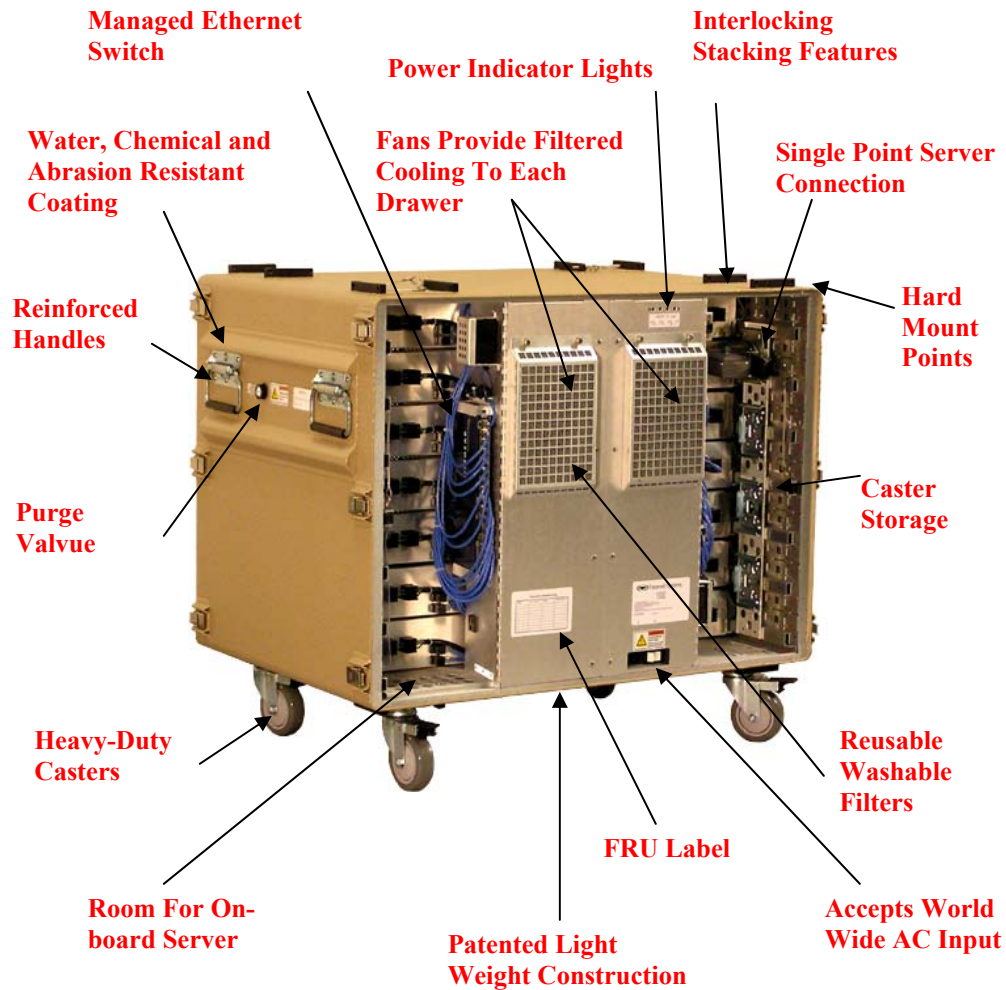

Ask About The Optional 5 Year Warranty

E-Tool Mobile Manager Specifications

System Specification:

- Operating Temperature : 0C - +50C
- Dimensions : Without Casters (H) 28" (W) 39" (L) 29"
With Casters (H) 33" (W) 39" (L) 29"
- Universal input Power : 90-264 VAC, 47-440Hz, 15A Max, Single Phase
- Rugged Enclosure Design incorporates, spring loaded recessed handles and rugged, abrasion & corrosive resistant coating.
- Unit equipped with a managed Ethernet switch
- Weight: approx. 210lbs (empty)

System Monitors :

- Fan Fail
- Fan Speed
- Temperature
- Input Power
- Current Draw

Rack System :

- 14 E-Tool Charging / LAN Interface Trays
- Variable Speed Fans Provide Cooling To Each Tray
- Pre Wired for CAT 5
- Washable Air Filters

Power System :

- Surge Protected, Conditioned Power
- Over-Temperature Shutdown
- Universal AC Input Voltages Are Converted To Filtered And Regulated 115V/60Hz AC Powering Each Tray

Common Rugged Docking Trays : (14)

- 11" Clearance When Fully Extended
- Tray Dimensions : (L)16.4" (W) 15" (H) 3.25"
- Open Provide Easy Access To E-Tools
- Single Point Locking Mechanism Locks All Drawers
- Adjustable & Secure Strapping System Secures E-Tools For Shipment